

T-FINISHING

Fully automated cell for ingot marking and quality control

WHAT IS T-FINISHING?

Is an all marking system that includes includes a hydraulic press for the logo stamping and a micro-dot marking machine for the serialization of numerical data. However, thanks to its circular shape, the machine can be equipped with many integration tools, such as the laser marking machine or an optical visor (T-Photo Viewer) for quality control.

With the T-Finishing™ process, it is possible to stamp the serial number and mark the company's logo on gold and silver ingots of various size.

This system can significantly increase production levels, optimize time dedicated to each process and reach full autonomy, can be equipped with a robot which can pick and place ingots on the automated cell.

HOW DOES IT WORK?

1. INGOT PLACING: The standalone version of T-Finishing does not include an analytical weight measurement cell (scale). Therefore, it is assumed that the operator checks the weight of the ingot before putting it in the inlet conveyor belt of the T-Finishing.

2. INGOT STAMPING: The first station to which the ingots arrive is the T-Press.

- ◆ The rotating table brings the ingot under the stamping die, positioning it in the dedicated working area.
- ◆ The press detects the presence of the ingot and carries out the stamping.
- ◆ Upon its completion, the table activates again, bringing a new ingot under the stamping die and moving the one already stamped to the following station.

3. INGOT MARKING: The second station is the T-Numbering machine, where the ingot is serialized according to the customer's requests.

4. INGOT OUTPUT: At the end of all operations, the rotating table brings the ingot to the outlet conveyor belt, where it will be picked up by the operator.

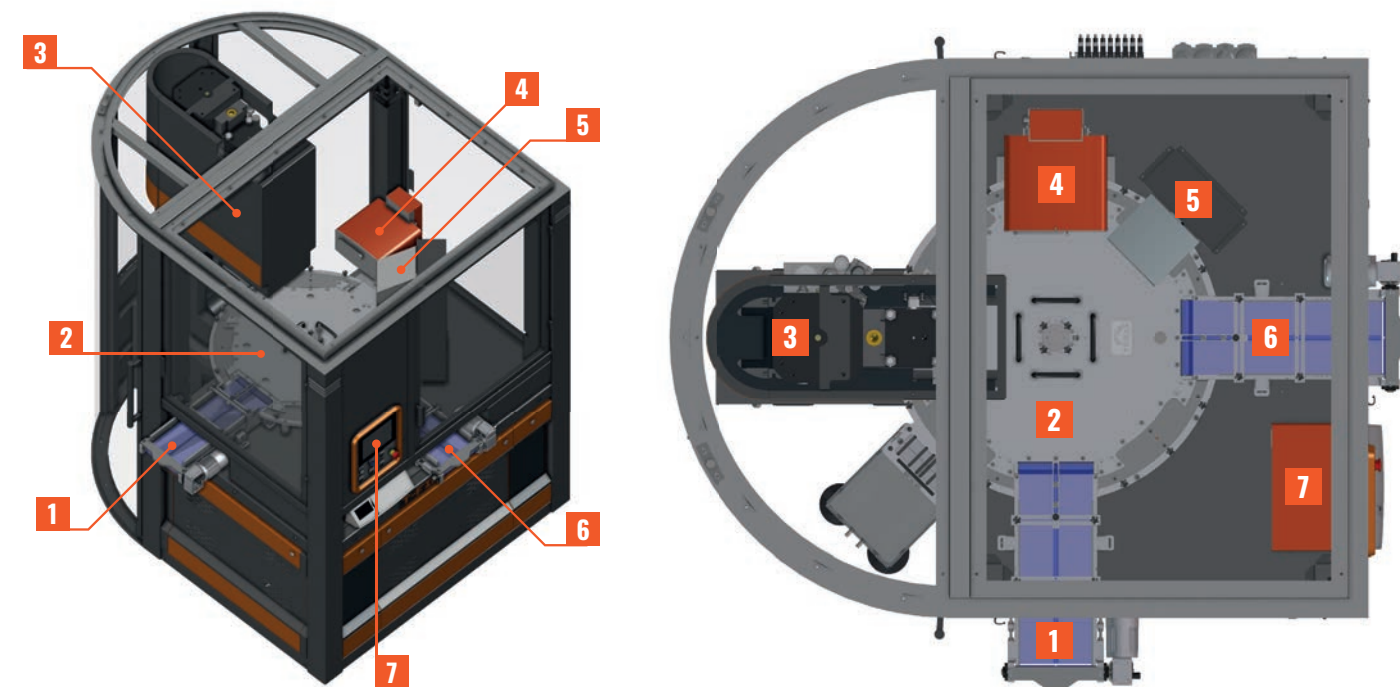

1. Inlet conveyor belt
2. Rotating table
3. T-Press 33 tons
4. T-Numbering
5. T-Photo Tracker vision system with OCR for quality control
6. Outlet conveyor belt
7. T-Numbering controller

FOCUS ON ELEMENTS



INTERCHANGEABLE TEMPLATES

Thanks to a re-engineering of the rotating carousel, the bar design changeover operation in the range going from 50 gr. to 100 oz is now much faster thanks to a magnet template which ensures a strong locking.

For each bar size a set made of n°8 quick-change inserts is available allowing fast and neat changeover. Thanks to this innovative solution the operator only needs to pull out the old inserts and position the new ones for different bar size.

T-ECOPRESS 33 Tons

A high quality "C" shaped pneumo-hydraulic 33 Tons power press is integrated in the T-Finishing to ensure a consistent and precise logo application over all bars.

The use of a pneumatic driven press is a milestone in ecological approach of minting bars, is also reliable for maintenance since there is no hydraulic pump unit which was necessary in the older version.

T-Finishing is supplied already equipped with full tooling for 1 bar design (to be indicated by the client), including quick-change magnetic sets, universal stamp holder and stamping tool.

Au/Ag Bars output	From 120 to 500 pcs/hour (Production range may vary according to number of digits, font, pressure and thickness of marking machine)
Processed bars in automatic mode	From 50 g to 100 oz
Processed bars in manual mode	Over 100 oz



T-NUMBERING

T-Numbering is microdot marking device for personalized serialization of ingots and printing of company logos.

With this machine, in a very compact size, you have the possibility of printing logos, serial numbers or customized lettering on metal surfaces.

The T-Numbering marking system does not create engravings, but rather micro-hammers. There is therefore no removal of metal, only crushing. The absence of metal loss is the greatest advantage of this machine.

THE BENEFITS OF AN INNOVATED, AUTOMATED SOLUTION:



Press and numbering machine integrated in one module.



Finishing of large volumes in short time and automatically.



Increased safety level for the operators.



Possibility of total automation with the integration of a robot and quality control.

ACCESSORIES:



STAMPING DIES AND STAMP HOLDERS

For high-quality results, press stamps can be customized according to:

- ◆ ingot design
- ◆ graphical elements to be stamped



QUICK-CHANGE MAGNETIC INSERTS

T-Finishing requires full set of magnetic inserts suitable for processing each bar size. Sets of inserts for any bar size are available for both manual and automated procedure (according to bar size).



T-PHOTO VIEWER

Is a vision system that can be programmed for a quality logo stamping control for OCR and OCV serial checking. Is also possible to stamp a photo on the bar and store in a data logging REP.



T-ROUTER

T-Router allows a remote access for diagnostics and control operations, modifications and software updates to Tera Automation's machinery anywhere in the world. There is no need for additional software.

Directly from our technical office we can access to the PLC of the connected equipment, having the possibility to analyze the failure, managing its solution and updating the software.

This device requires internet connectivity, either wired or Wi-Fi or possibly via a SIM card, depending on the needs of the customer.

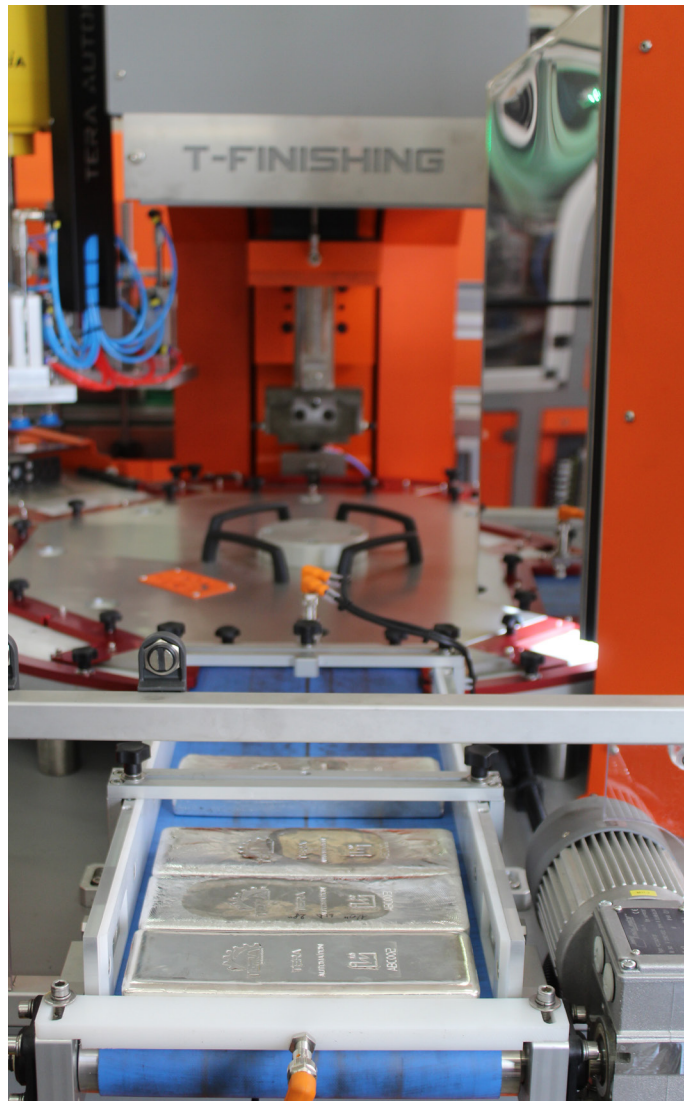

OUR PASSION FOR YOUR EVOLUTION

TERA AUTOMATION SRL
Via Romena 7/9, Loc. Porrena
52014, Poppi (AR), Italy
VAT: IT01979320510
Phone: +39 0575 536625
www.tera-automation.com | tera@tera-automation.com

Stampa_Gennaio 2024

Tera Automation S.r.l. declares that the data and/or images in the brochure do not constitute an infringement of other people's intellectual or other property rights.



T-FINISHING



Full automated cell for ingot marking and quality control